

MAKE THE POSSIBILITY



JEMT Co.,Ltd

대한민국 금형의 역사



대한민국은 세계에서 가장 크고 품질 좋은 금형 제조국이다. 그리고 모든 것은 대한민국 조상들로 인해 천 오백년 전에 시작되었다.

• 위 사진은 천 오백년 전에 만들어진 가지 타입의 찍는 금형이다.



• 오른쪽 사진은 천 오백년 전에 만들어진 제품이다.



회사 소개

JEMT는 인천공항으로 부터 75km 정도 떨어진 곳에 위치하여 자동차 부품, 생활용품, 전자제품 등의 금형을 제작 기반으로 빠르게 성장하고 있는 회사이다.
고객에게 최고 품질의 금형과 최상의 서비스를 제공하겠다는 정신이 JEMT의 모토이다.
우리는 항상 이 모토를 바탕으로 전직원이 합심하여 금형을 제작 하고 있으며 최근에는 자동차용 Bumper, Instrument Panel과 같은 대형 금형을 제작함으로써 우리의 사업 영역을 확장하고 있다.

- 위치 : 화성
- 총 평수 : 3,300 M²
- 공장 평수 : 2,000 M²
- 연간 제작량 : 200 sets



회사 연혁

- 2003.03 조은몰텍 설립(경기군포)
- 2003.12 ISO9001/14001 인증(IAF)
- 2004.06 쌍용 SSQ 인증
- 2006.03 (주)제이 이 엠티(JEMT) 법인전환
- 2006.11 현대/기아 SQ 마크 인증
- 2008.04 자본금 증자 (7억6천4백)
- 2009.03 본사 이전(현 화성공장)
- 2010.08 GM GPPC 인증 (1500TON)
- 2012.01 사출 양산공장 신설(1300TON \times 150TON, 총10대)
- 2014.06 시험사출동 증설((1800,1300,750,450,220 Ton))
- 2015.03 태국지사 설립 (촌부리)

인증 현황

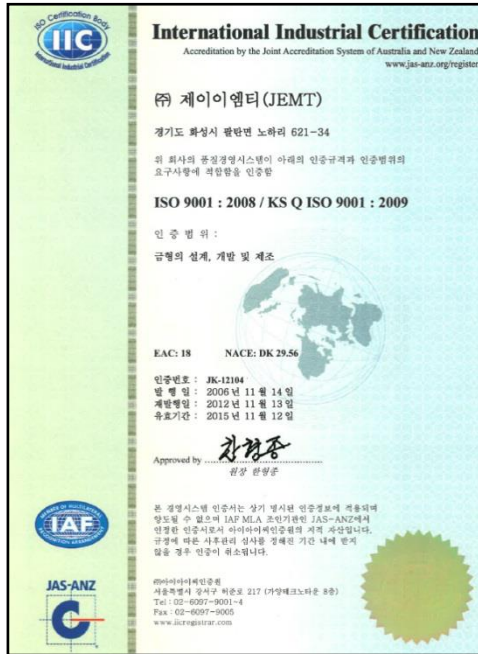

ISO9001/14000(IAF)



GPPC(GM)

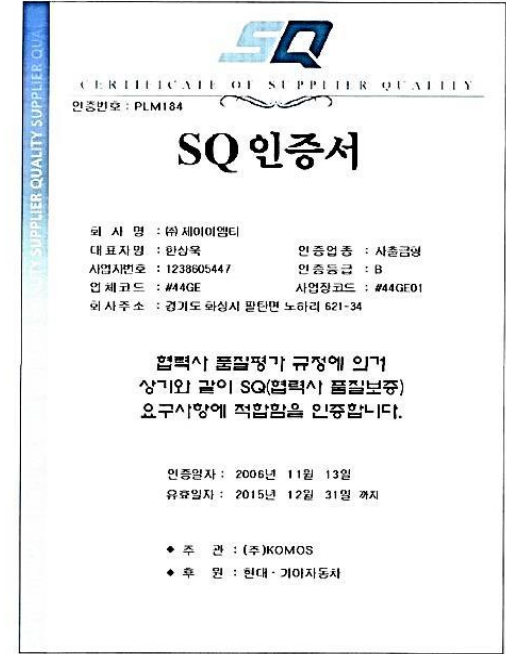

SQ(현대/기아)

Organization

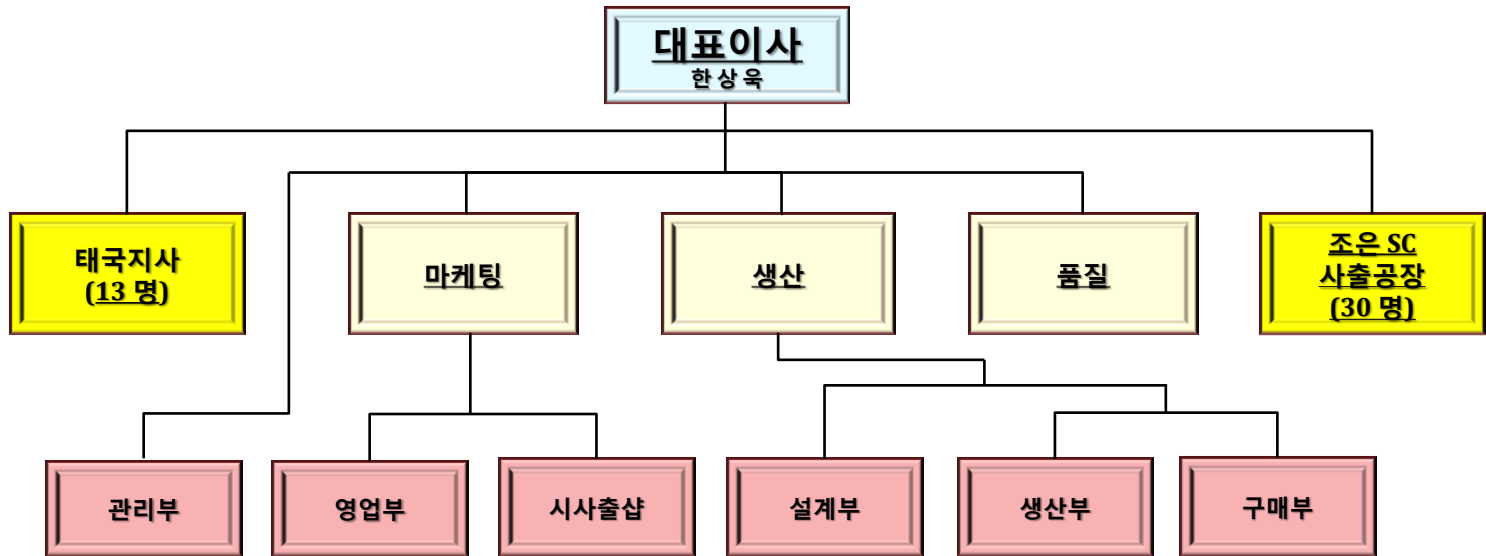

	설계	영업	품질	기계	사상/조립	시사출	기타	총
2015	6	6	1	12	10	3	4	42
2016	9	7	2	13	16	3	5	55

매출 현황

년도	2012	2013	2014	2015	2016(목표)
총매출	78억 원	65억 원	90억 원	85억 원	120억 원
수출	17.5%	11.6%	20.1%	25.0%	30.0%
국내	82.5%	88.4%	70.9%	75.0%	70.0%

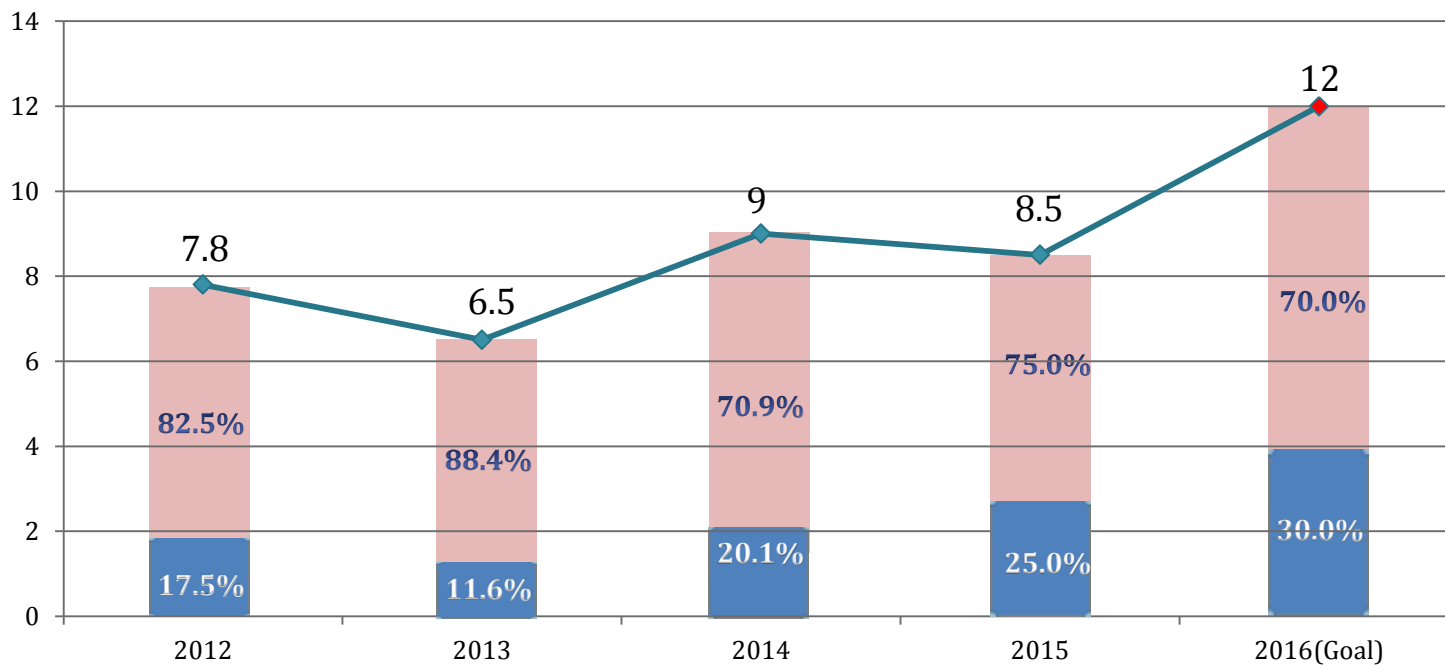

매출량

국내

	GMK	현대기아	르노삼성	쌍용
2014	44.0%	19.1%	13.4%	3.0%

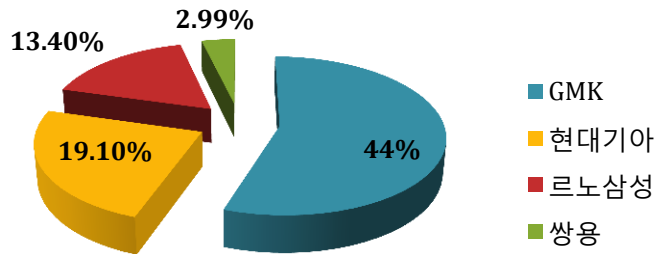

해외

	인도	일본	중국	기타
2014	56%	23%	11%	10%

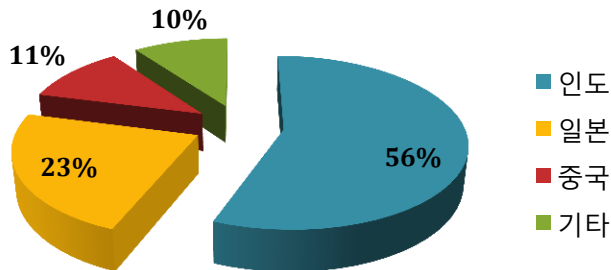

제품별

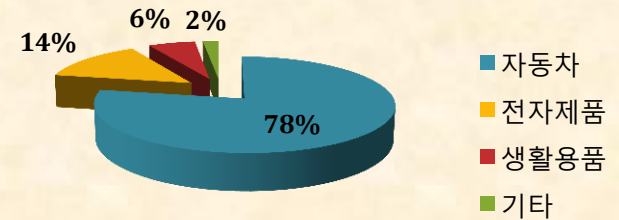

자동차 : 78%
 전자제품 : 14%
 생활용품 : 6%
 기타 : 2%

설계

소프트웨어	코피량
UG 7.5	6 세트
Auto CAD	6 세트
Mold Flow	1 세트
Power Mill V.11	5 세트
CAD Max	4 세트

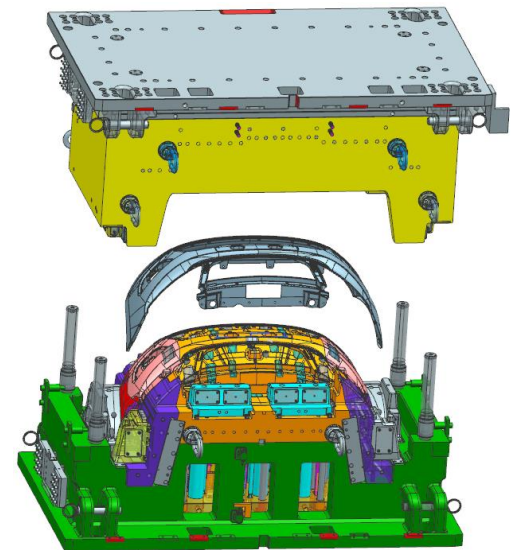
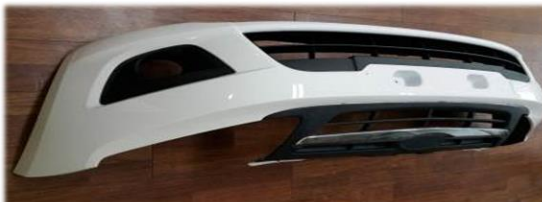
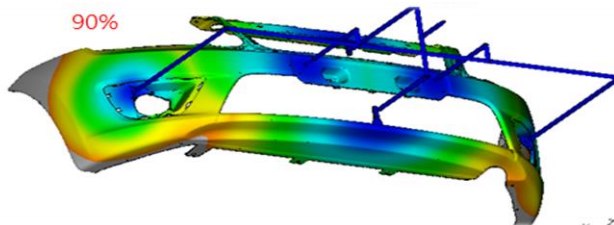
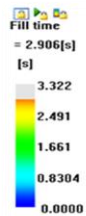

CNC



기계	모델/크기	회사	수량	개요
CNC Boring M/C	KURAKI KBT-13E-A	Kuraki	1	IP, Bumper 용
CNC M/C	SIRIUS-2500	화천	1	IP, Bumper 용
CNC M/C	SIRIUS-1250	화천	1	
CNC M/C	VM925	두산	1	
CNC M/C	VM70H	두산	1	
CNC M/C	VM560	두산	1	
CNC M/C	SMART-Ua 20,000	화천	1	그래파잇
CNC M/C	SIRIUS UL	화천	1	그래파잇
CNC M/C	UH 500	화천	1	32,000RPM 5월 입고

EDM & Die Spotting & 기타



기계	모델/크기	수량	회사	개요
CNC EDM	대	1	대한	2-Headed
CNC EDM	대	1	Makino	
CNC EDM	중	1	대한	
CNC EDM	소	1	대한	
CNC EDM	소	1	Makino	
Die Spot	200TON	1	극동	
Die spot	400TON	1	CMTI	
Milling	HMT-1100T	2	화천	
Lathe	HL-380	1	화천	
Grinding M/C	HIL-G-501	1	한일	
Radial M/C	DRD-1100	1	두산	

크레인 & CMM

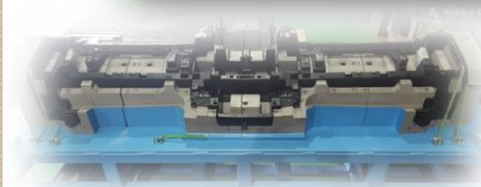
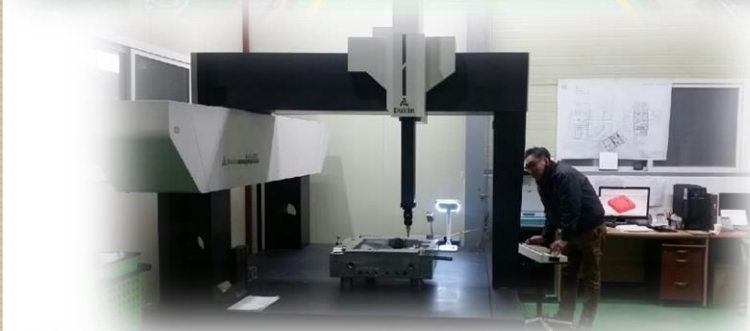

기계	모델/크기	회사	수량	개요
Hoist	25TON	남해	1	
Hoist	20TON	남해	1	
Hoist	10TON and below	남해	7	
Hoist	35TON		1	검토중
CMM M/C	MHB	덕인	1	
Mold Reversing Machine	MAX 35TON		1	

사출기

기계	모델/크기	회사	수량	개요
사출기	3000TON	우진	1	검토중
사출기	1800TON	LS엠트론	1	시사출용
사출기	1300TON	Mitsubishi	1	시사출용
사출기	700TON	우진	1	시사출용/ 양산
사출기	450TON	현대	1	시사출용 /양산
사출기	220TON	LG	1	시사출용 /양산

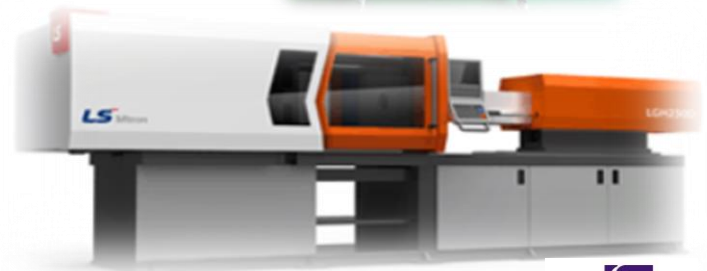

자동차 부품 (외관)

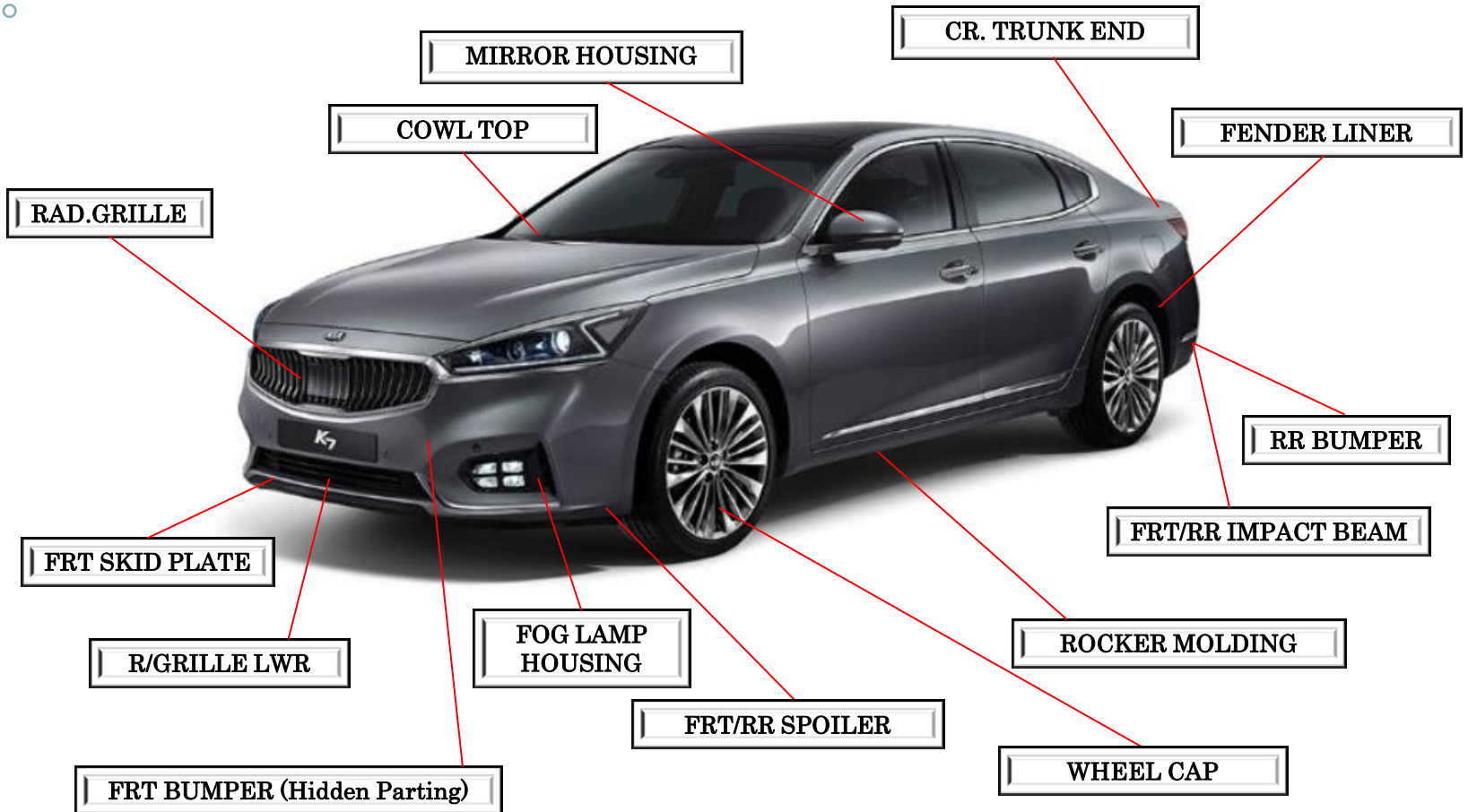

자동차 부품 (외관)

- Bumper

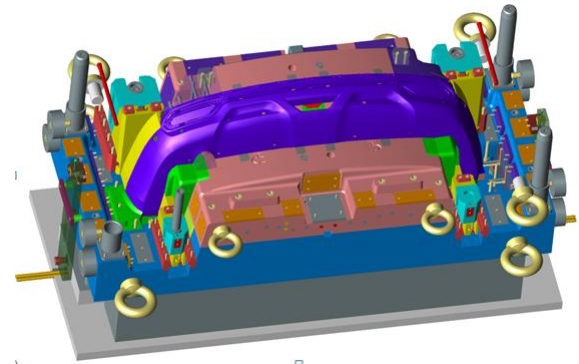

- Spoiler



- Impact Beam



자동차 부품 (외관)

- Radiator Grille



자동차 부품 (외관)

- Cowl



- Fog Lamp Cover

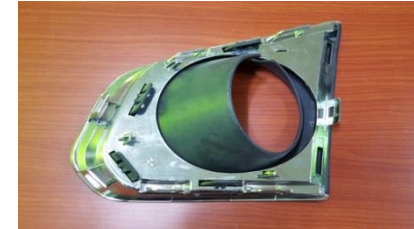

- Fog Lamp Housing



- Fender Liner



- Mirror Housing



자동차 부품 (외관)

- Under Cover



- Wheel Cap



- Over Fender



- Molding



자동차 부품 (내장제 품)

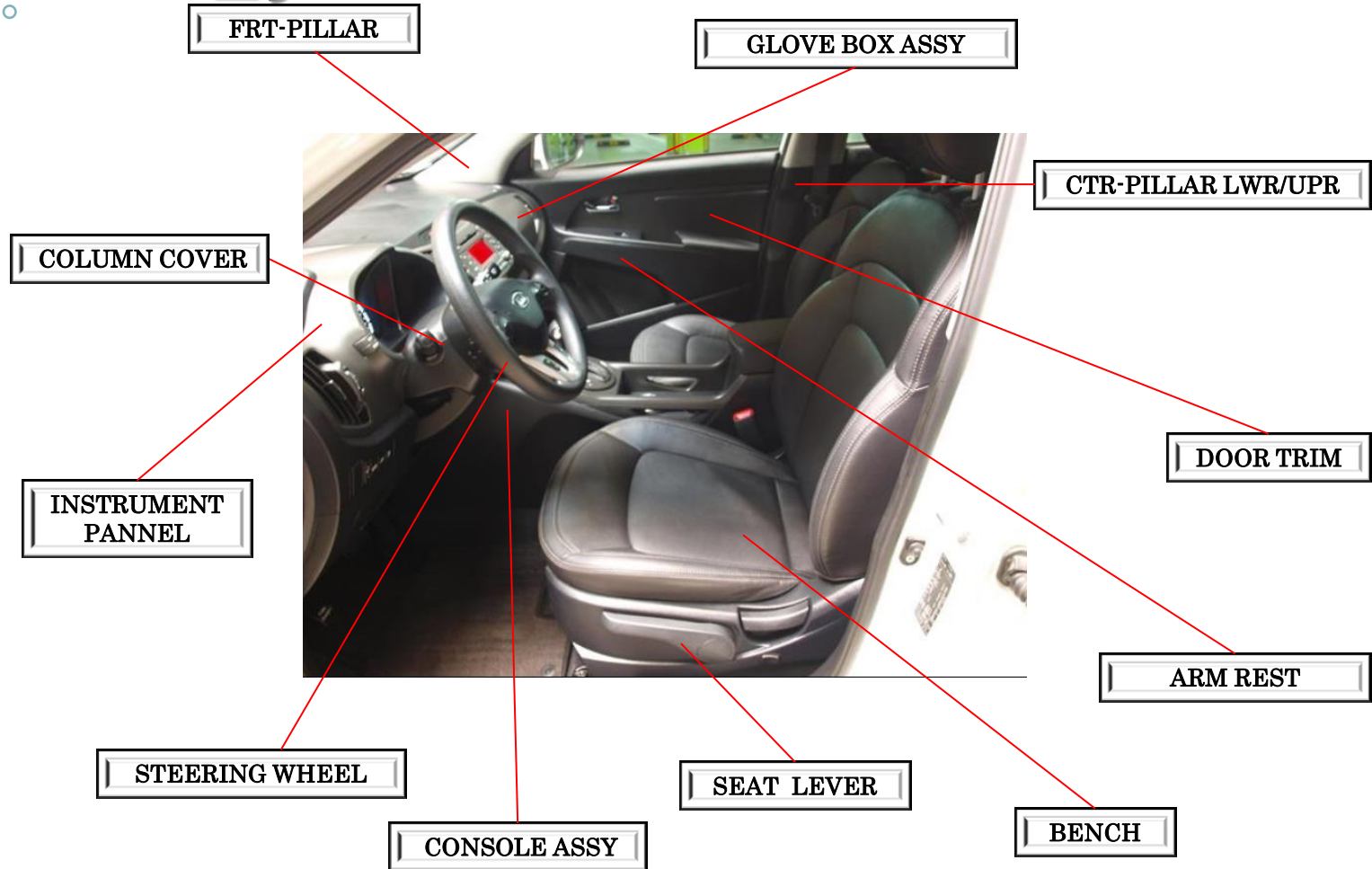

자동차 부품 (내장제 품)

- I/P & Parts

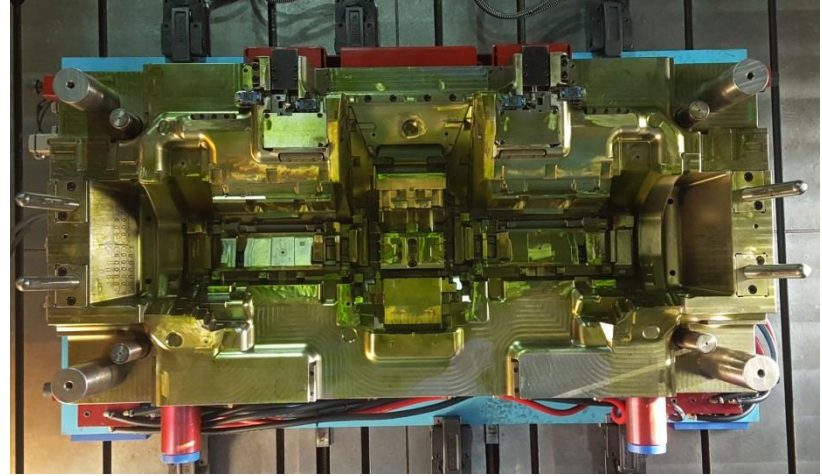

- Glove Box



자동차 부품 (내장제품)

- Console



- Map Pocket



- Door Trim



- Switch Pannel



자동차 부품 (내장제품)

- Pillar



- Cup Holder



자동차 부품 (내장제품)

- Bench



- Gear Housing



- Steering Wheel



- Cover Shield



자동차 부품 (에어컨 & 엔진부품)

부품
FAN
SHROUD
CASE CONDUCTOR UPR
CASE LWR BLOWER
CASE HEATER
CASE LWR FILTER
RAD. TANK
UPR TANK



자동차 부품 (에어컨 & 엔진부품)

• Heater Case



• Fan



• Shroud

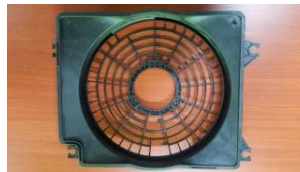

전자제품

- Refrigerator



- Washing M/C



- Two Shot



전자제품

- Projector

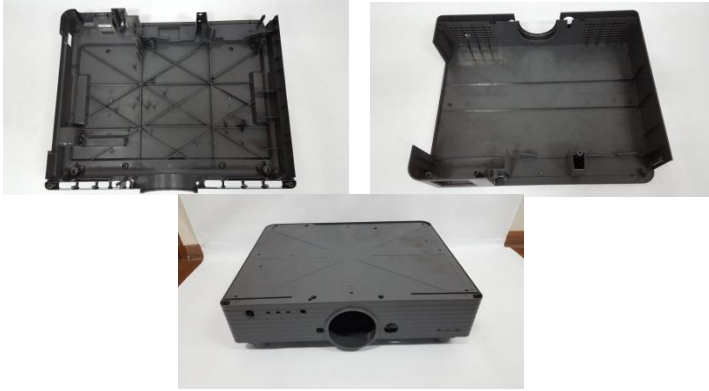

- TV



- ATM

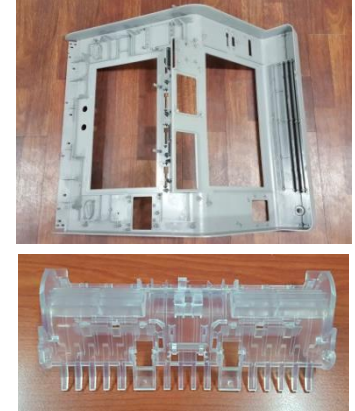

- ETC

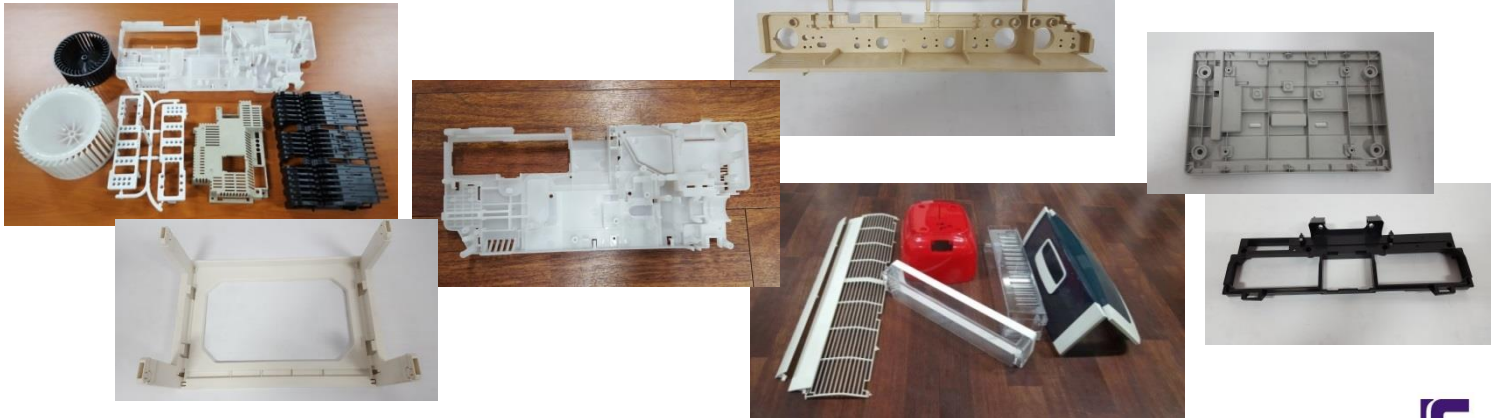

생활용품

- Box



- Chair



- Daily Products



- Etc

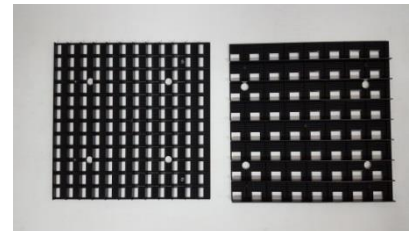

고객사

국적	회사
한국	현대/기아, GMK, 르노삼성, 쌍용, Visteon
	NS-Auto, 우경, 세코
	KB Auto Tech, 용산
인도	Tata, Visteon, TACO
유럽	Antolin
러시아	ABTOBA3





**MAKE THE
POSSIBILITY
MAKE THE
PERFECTION**

Thank You

JEMT Co.,Ltd

JE
JO EUN MOLD-TECH